

Model 8060 has three (3) separate valves that address pressure/vacuum conditions in underground storage tanks (UST).

- Husky pressure / vacuum (P/V) vents incorporate three (3) separate valves to control over-pressure and vacuum conditions that arise in storage tanks. The three (3) valve system provides the necessary protection and durability needed in a UST vent cap.
- The vacuum valve is diaphragm operated and provides ten (10) times more sealing force than gravity devices. It constantly opens at 8" - 10" of water column (WC) / 2 - 2.5 KPa vacuum.
- The first over-pressure valve is diaphragm operated, giving ten (10) times more sealing force than gravity devices. It opens at 3" - 6" WC / .75 - 1.5 KPa pressure.
- The safety over-pressure valve is designed to handle high pressure / high flow conditions. This valve will vent up to 7900 SCFH at 2 psi / .14 bar.
- Threaded vent cap that is easily installed by using the cast-on hex nut which allows tightening without having to go between vent pipes.
- Not for use in California / EVR applications.

Pressure/Vacuum Vents

MODEL NO.	DESCRIPTION	SHIPPING WEIGHT LBS (KG)
8060	2" / 51 mm Thread-On Pressure / Vacuum Vent Cap	1.2 (.54)

Construction

Body	Aluminum
Screen	40 Mesh Stainless Steel
Set Screws	Stainless Steel
Deflector	Aluminum



This component was tested to and met the following criteria:

PRES. 3-6 IN. W.C.

VAC. 8-10 IN. W.C.

.05 CFH @ +2 IN. W.C.

.21 CFH @ -4 IN. W.C.





All Pressure/ Vacuum Vents have three (3) separate valves that address pressure/vacuum conditions in underground storage tanks.

Dimensions and System Options

Adapter

MODEL NO.	DESCRIPTION
5041	3 in / 76 mm Thread to 2 in / 51 mm Thread Pipe Adapter

Testing Equipment

MODEL NO.	DESCRIPTION
5426	Pressure / Vacuum Vent Test Adapter

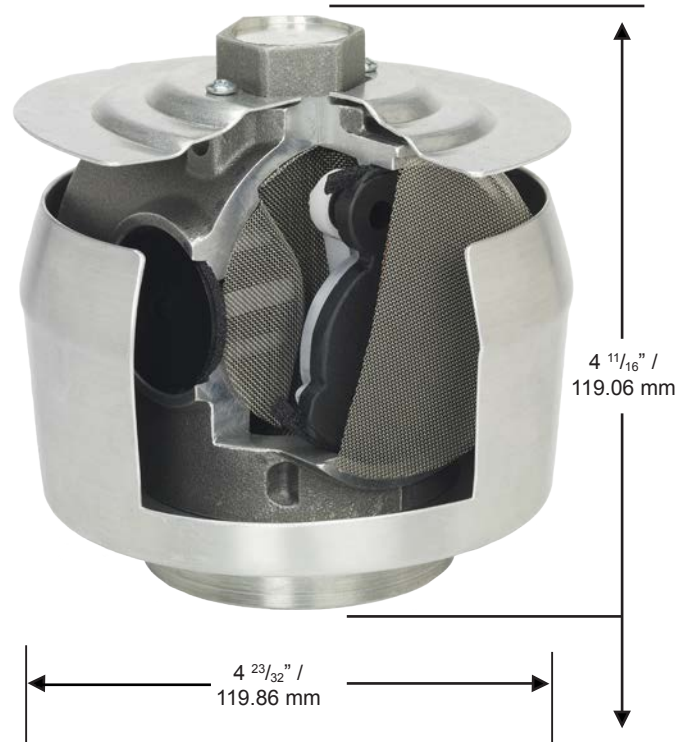

2325 Husky Way • Pacific, MO 63069
 (800) 325-3558 • Fax (636) 825-7300
www.husky.com • sales@husky.com

MADE IN THE U.S.A.

All Pressure/Vacuum Vents have three (3) separate valves that address pressure/vacuum conditions in underground storage tanks.

Model 4620 and 4885

- The three (3) valve system provides the necessary protection and durability needed in a UST vent cap.
- The vacuum valve is diaphragm operated and provides ten (10) times more sealing force than gravity devices. It consistently opens at 6" - 10" of water column (WC) / 1.5 - 2.5 KPa vacuum.
- The first over-pressure valve is diaphragm operated, giving ten (10) times more sealing force than gravity devices. It opens at 2.5" - 6" WC / .63 - 1.5 KPa pressure.
- Not for use in California / EVR applications.
- Model 4885 is certified to less than 1/3 of the CARB EVR Standard CP-201 which allows installation of three (3) P/V Vents maximum. This reduces installation time by not having to manifold the vent pipes together.
- Model 4885 is a threaded vent cap that is easily installed by using the caston hex nut which allows tightening without having to go between vent pipes.

- Model 4620 is a slip-on vent cap with a main pliable seal that seals to the vent stack and provides leakproof protection because the seal is at the end of the vent stack, not on the threads.
- Model 4620 uses four (4) stainless steel set screws to grip the vent stack preventing any loosening of the seal.

Model 5885

- Has an internal screen to protect the pressure plate in the event of a bad bulk drop.
- The safety over-pressure valve is designed to handle high pressure / high flow conditions. This valve will vent up to 7900 SCFH at 2 psi / .14 bar.
- Certified to less than 1/3 of the CARB EVR Standard CP-201 which allows installation of three (3) P/V vents maximum. This reduces installation time by not having to manifold the vent pipes together.
- Has a threaded vent cap that is easily installed by using the cast-on hex nut. This also allows tightening without having to go between vent pipes.

Pressure/Vacuum Vents

MODEL NO.	DESCRIPTION	SHIPPING WEIGHT LBS (KG)
4620	2 in / 51 mm Slip-On Pressure / Vacuum Vent Cap	1.2 (.54)
4885	2 in / 51 mm Thread-On Pressure / Vacuum Vent Cap	1.2 (.54)
5885	2 in / 51 mm Thread-On Pressure / Vacuum vent Cap with internal screen	1.2 (.54)

Construction

Body	Aluminum
Screen	40 Mesh Stainless Steel
Internal Screen	40 Mesh Stainless Steel (5885 only)
Set Screws	Stainless Steel
Deflector	Aluminum



This component was tested to and met the following criteria:

PRES. 2.5-6 IN. W.C.
VAC. 6-10 IN. W.C.
.05 CFH @ +2 IN. W.C.
.21 CFH @ -4 IN. W.C.



Texas Commission on Environmental Quality



California Environmental Protection Agency
AIR RESOURCES BOARD

All Pressure/Vacuum Vents have three (3) separate valves that address pressure/vacuum conditions in underground storage tanks.

Dimensions and System Options

Adapter

MODEL NO.	DESCRIPTION
5041	3 in / 76 mm Thread to 2 in / 51 mm Thread Pipe Adapter

Testing Equipment

MODEL NO.	DESCRIPTION
5426	Pressure / Vacuum Vent Test Adapter

